

Installation manual

Pipe Cover

For Bosch Aquastar Models: GWH 2400 ES, GWH 2700 ES

For Bosch ProTankless Models: GWH 715 ES, GWH C 800 ES, GWH C 920 ES, GWH C 920 ESC



BOSCH

Invented for life

Table of Contents

1	Introduction	4
1.1	Items included with Pipe Cover kit	4
1.2	Tankless Water Heater compatibility	4

2	Installation	5
---	--------------	---

1 Introduction

1.1 Items included with Pipe Cover kit:

See Figure 1

- Front Panel (1)
- Right side panel (1)
- Left side panel (1)
- Bottom Panel (1)
- Machine screws (10)
- Self tapping screws #8 (4)

1.2 Tankless Water Heater compatibility

The Pipe Cover kit is compatible with the following Bosch tankless water heaters:

- GWH 2400 ES (part number: AQPCES)
- GWH 2700 ES (part number: AQPCES)
- GWH 715 ES (part number: PTPCES)
- GWH C 800 ES (part number: PTPCES)
- GWH C 920 ES (part number: PTPCES)
- GWH C 920 ESC (part number: PTPCES)



The pipe cover cannot be used with any Bosch GWH 635 ES, GWH 635 ESO, AQ 250 SX, AQ 250 SXO, GWH 2400 E, GWH 2400 EO models

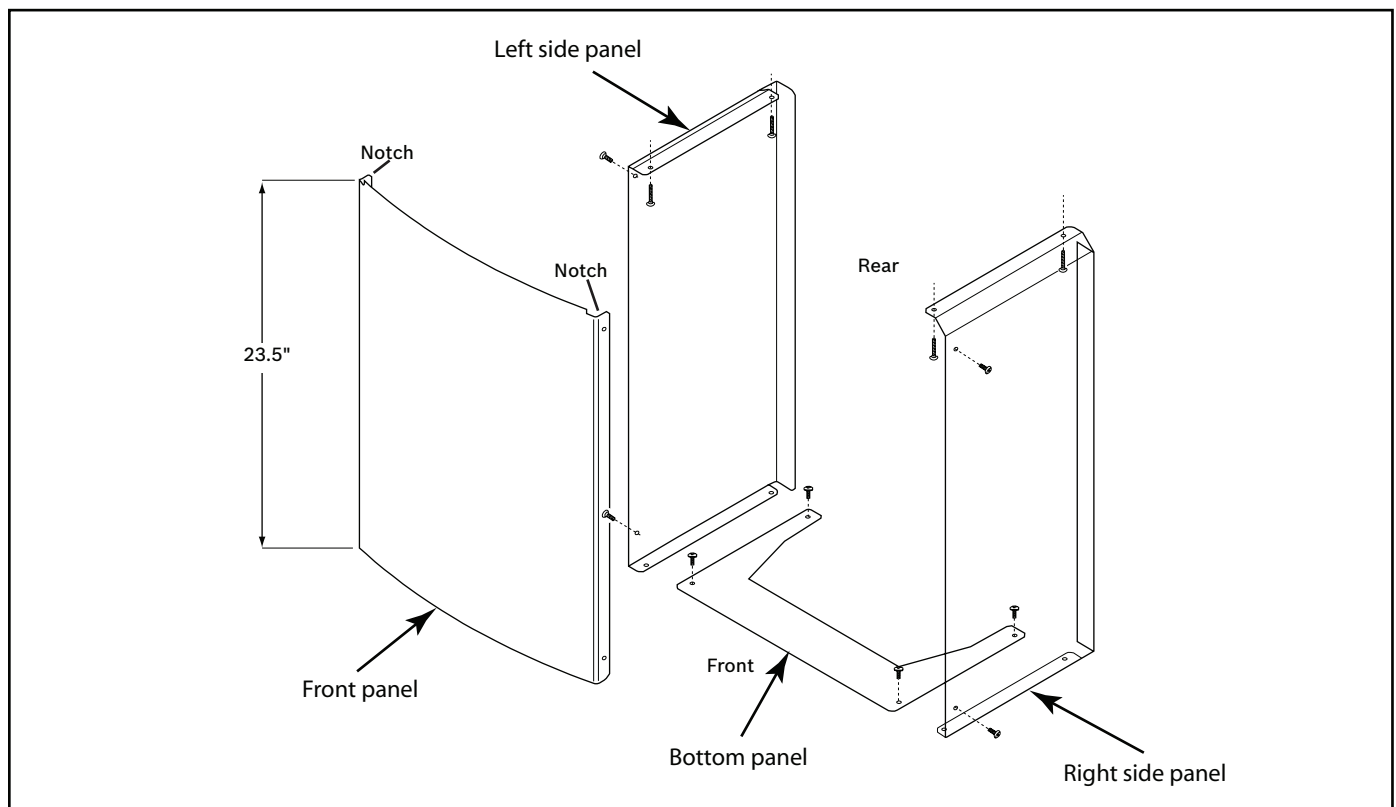

Fig. 1 Pipe Cover kit components overview

2 Installation

1. Ensure all items listed in Section 1.1 are complete.
2. Water heaters listed in Section 1.2 with date codes FD984 and later are equipped with screw holes for the pipe cover. The FD code is the first 3 numbers in the appliance's serial number (see Fig.2, pos. A). For all earlier models, use the bottom panel of the pipe cover as a template to drill four $\frac{9}{64}$ " diameter holes into the bottom of the water heater. (See Fig. 3).

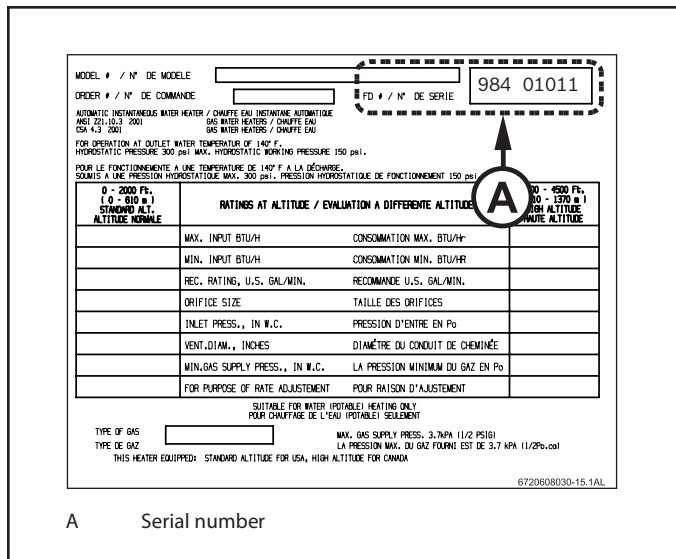

Fig. 2 Rating plate sticker with serial number (right side of heater)

3. For heaters without pre-drilled holes, place the water heater on its back with the front cover removed. Position bottom panel of pipe cover over the bottom of the water heater being sure to line up flush where indicated (See Fig. 4). Once aligned, mark the four holes in the bottom panel for drilling. Remove bottom panel and drill four $\frac{9}{64}$ " diameter holes into the bottom of the water heater.

CAUTION:
Drill carefully ensuring not to damage components inside of the water heater casing

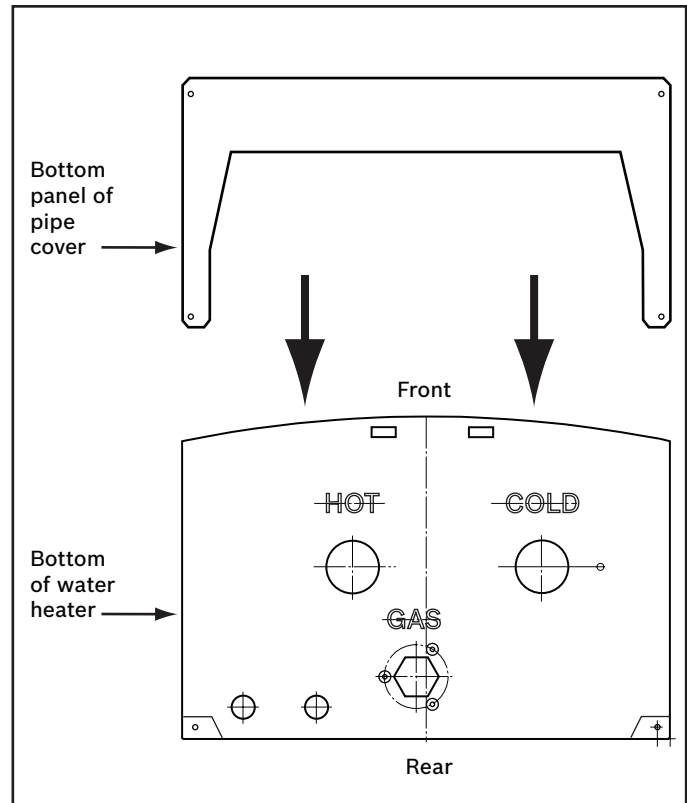

Fig. 3 Using bottom panel as drill template

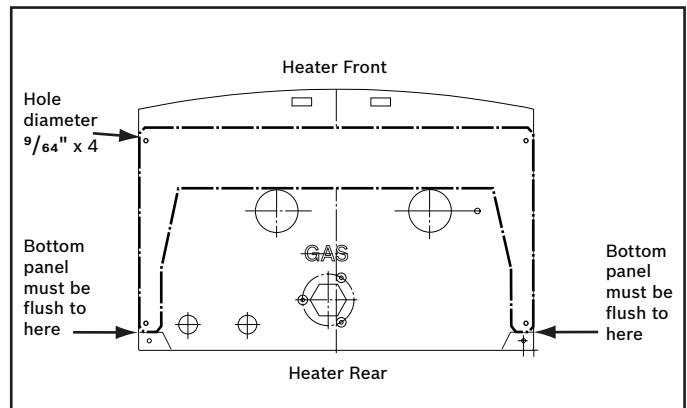

Fig. 4 Drill template alignment to water heater bottom

3. Hang the water heater following the appliance's installation instructions.
4. Complete the pipework. It is recommended to install an electrical junction box with an electrical outlet inside the pipe cover.

5. Install the water heater cover. Tighten the 2 screws at the bottom left and right.
6. Install the left side panel of the pipe cover with the right angle bends facing the wall and down. Tighten the screws to hand tight, then back out 1 turn. See Fig. 5.

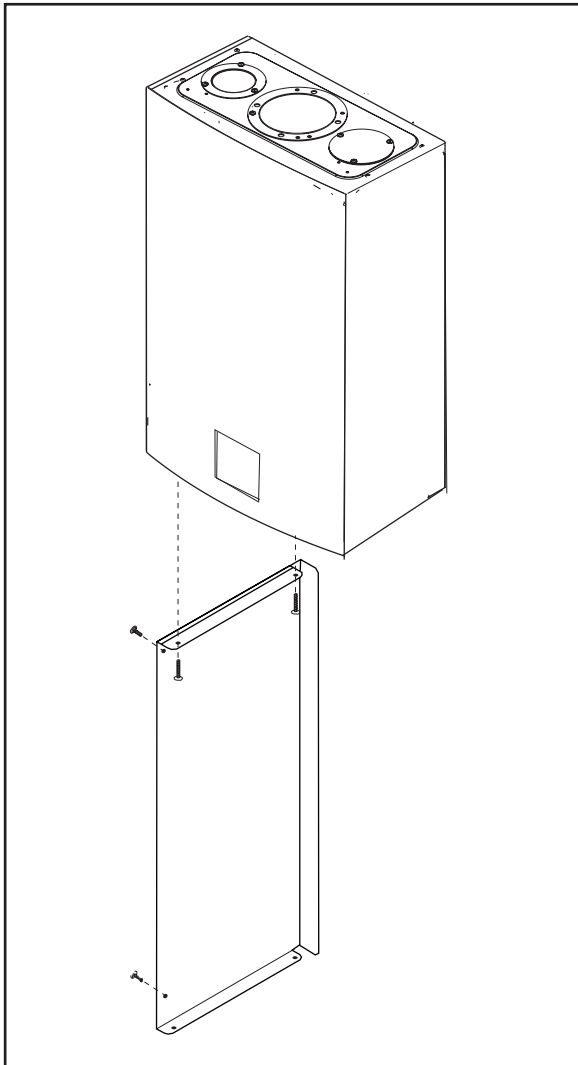

Fig. 5 Left side panel installation

7. Install the right side panel the same way. Tighten the screws to hand tight, then back out 1 turn.
8. Using four machine screws, mount the bottom panel on the inside of the flanges with the opening facing the wall. See Fig. 6.

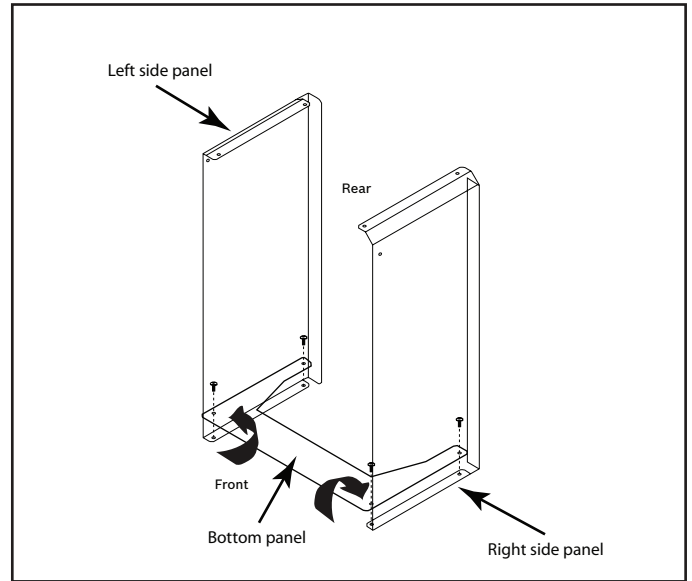

Fig. 6 Bottom panel installation

9. Ensure all panels are straight and plumb.
10. Finish installing the pipe work inside the pipe cover. The drain from the relief valve and the condensate drain (condensing models only) must extend below the pipe cover.
11. Fit the front panel with the 2 notches facing up. See Fig. 7.

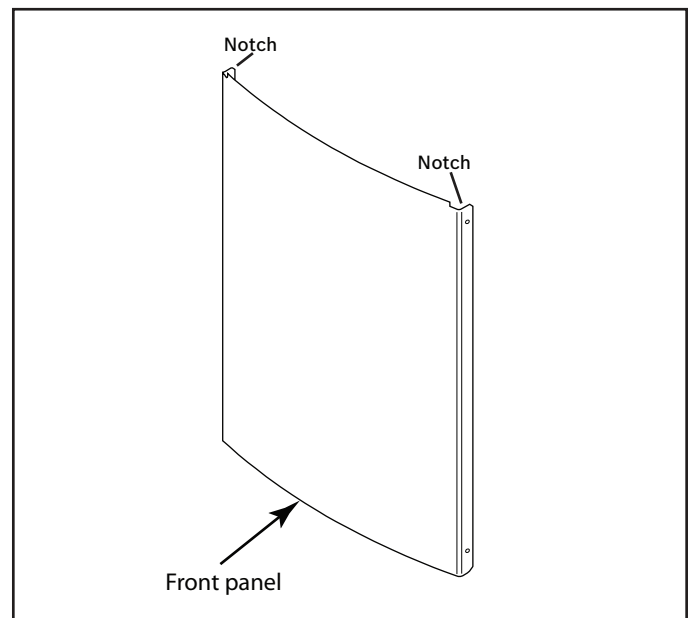

Fig. 7 Front panel

12. The upper radius of the front panel must be fitted behind the water heater's cover for proper installation (Fig. 8, pos.1). If necessary adjust the side panels to allow the front cover to fit properly. Once top of front panel is fitted behind the water heater's cover, swing bottom of front panel inwards (Fig.8, pos. 2). Ensure that the 4 screw holes line up with the threaded inserts on the side panels. Secure using four machine screws.

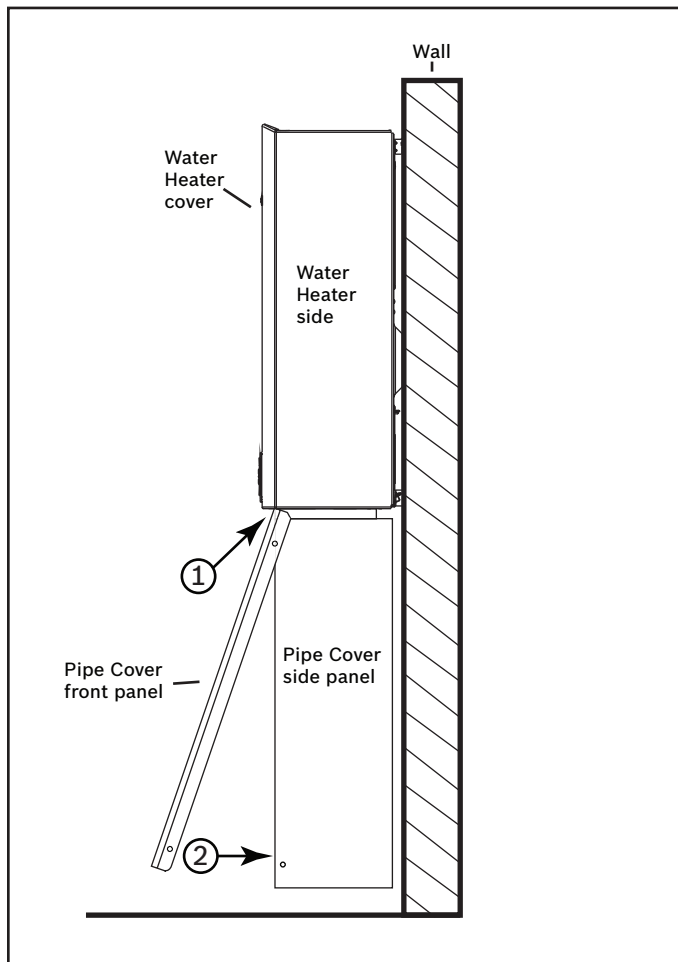

Fig. 8 Front panel installation

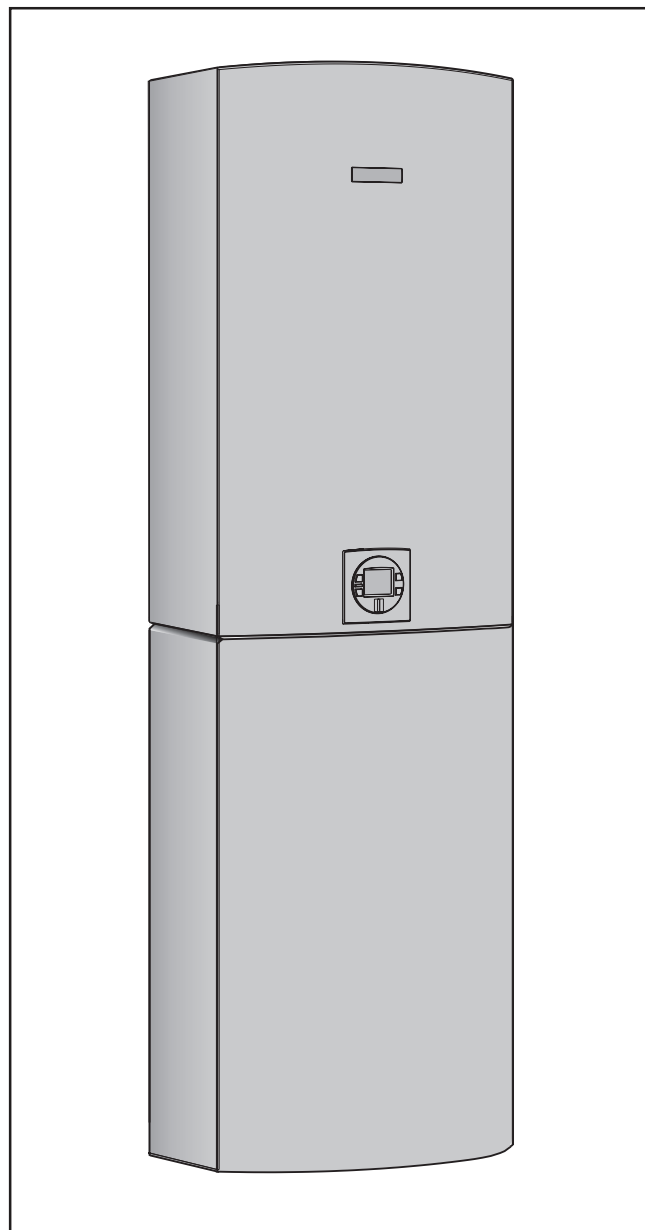

Fig. 9 Completed pipe cover installation

13. When fitting properly, tighten the attachment screws at the bottom of the water heater to hand tight. Then install and tighten screws for the front panel of the pipe cover. This installation is now complete (See Fig. 9).
14. On outdoor installations, install the outdoor vent conversion cap in accordance with the installation instructions included in the outdoor kit packaging.

Bosch Thermotechnology Corporation
50 Wentworth Avenue
Londonderry, NH 03053
Tel.: 800-642-3111
Fax: 603-584-1681
www.boschhotwater.com

BTC 710003301 A

Bosch Thermotechnology Corporation reserves the right to make changes without notice due to continuing engineering and technological advances.



BOSCH